

NWC604 Combi 2



COMBINATIONS

Norwell Combi 2 is a combination station of Chest and Back, this makes it possible to train both shoulders, back, chest, triceps and biceps.

Combi 2 uses your own weight as resistance. Giving just the right amount of resistance for safe and effective training.

HOW TO USE:

Back: When seated, place both your hands on the bar above you. Palms facing forward in a wide grip, as far as possible from the center of the bar. Pull yourself up by pulling the bar down, and try to get your head above the handlebar. The grip position can be changed to achieve more resistance. A closer grip equals more resistance. You can also try using just one arm.

The Norwell App and the ID-bands, including training instructions and QR codes, on each fitness station inspire to exercise and give full instruction of use.

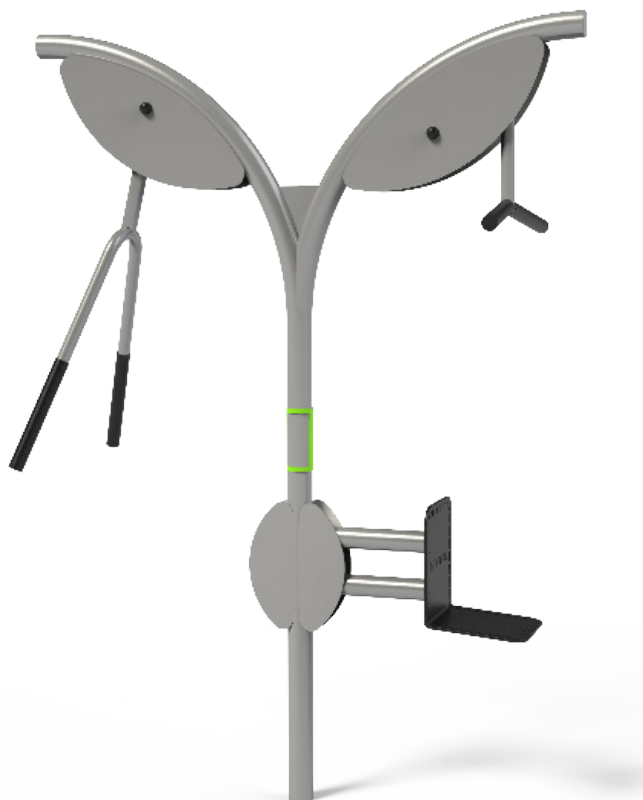

POSITION AND TRAINING ZONE:

Trainingzone = 15,6m² / 167,9 ft²

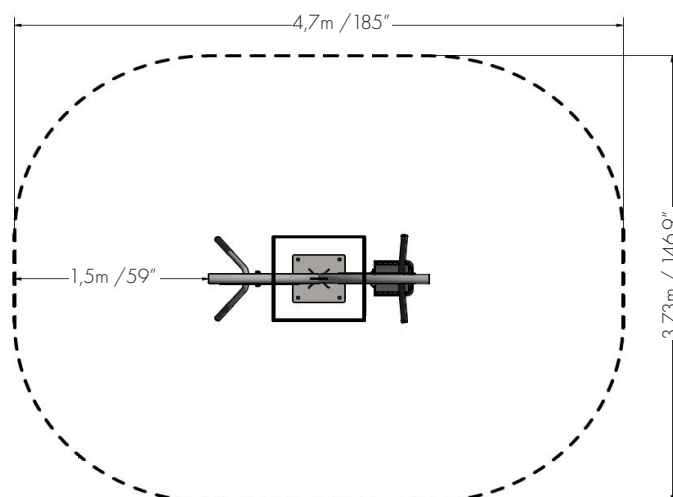

DESIGN FOR ALL

All Norwell fitness stations utilize the users own body weight as resistance, therefore the exercises can be performed without risk of injuries. As a result, Norwell fitness stations are challenging and effective regardless of fitness level.

SAFE DESIGN

The Norwell Outdoor Fitness stations are tested and approved by TÜV Product Service GmbH according to DIN79000, EN16630 and AfPS GS 2014:01 PA.

10 YEAR WARRANTY

10 years against failure due to material or manufacturing defects and corrosion breakthrough on pipes, foundations and welds. Please contact us for more information about warranty coverage, and for sites within 5 km of saltwater.

2 YEAR WARRANTY

2 years against failure due to material or manufacturing defects and corrosion breakthrough on all moving parts, plastic and rubber parts.